



## Techno-economics of micro-CHP

WP5 Presentation

24<sup>th</sup> September 2013

# Tasks

| Task                              | Brief description   |
|-----------------------------------|---|
| Task 5.1<br>Responsible: Element  | <b>Cost and market projections:</b> Cost and performance projections to 2030. Results will cater for assumptions regarding deployment volume.   |
| Task 5.2<br>Responsible: Element  | <b>Supply chain:</b> This task will consider the supply chain issues related to product manufacturing.  |
| Task 5.3<br>Responsible: Cogen    | <b>Policy:</b> A series of EU policy recommendations will be developed which reflect the lessons learned from ene.field.  |
| Task 5.4<br>Responsible: Imperial | <b>Macroeconomics/environment:</b> Task will examine the impact of mCHP on the electrical system for a future energy system scenario, including integrated system and environmental impact. |

# Deliverables

| Deliverables | Brief description   | Month of delivery |
|--------------|---|-------------------|
| D5.1         | Report on economics of mCHP to 2030 and uptake scenarios in each member state   | 46                |
| D5.2         | Report on the EU FC mCHP supply chain, potential bottlenecks and synergies between manufacturers  | 15                |
| D5.3         | Report on the Policy requirements for the commercialisation of mCHP, for members states and at a European level                                 | 48                |
| D5.4         | Report on the macro-economic and macro-environmental impact of FC mCHP on the energy system within member states participating in the programme | 40                |

## Contents of this talk

- Why FC micro-CHP – Context of the challenge
- An engineering-economic model of micro-CHP
- Optimal sizing
- Impact of building energy efficiency
- R&D insights
- Grid and energy system interactions

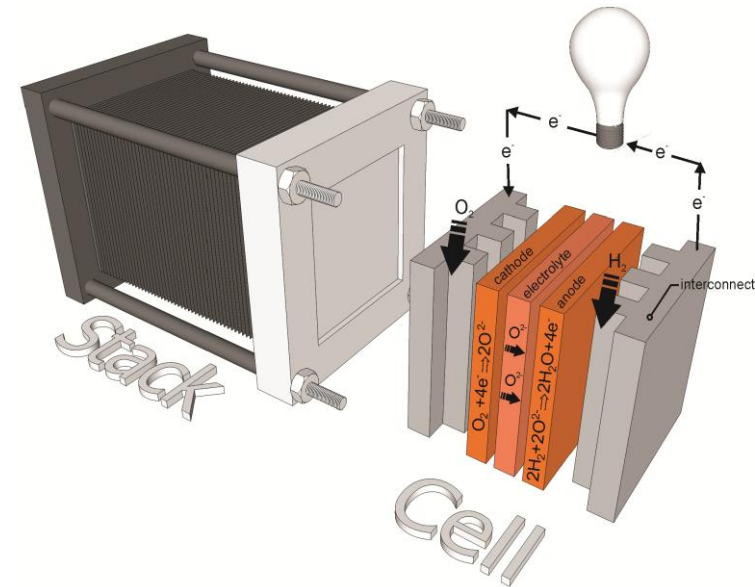

# Context of the challenge

1. Energy system decarbonisation (low grade heat virtually completely decarbonised)
2. Affordability and competitiveness (e.g. fuel poverty)
3. Energy security, reliability, resilience
4. ...all points towards radical energy system change in the next 4 decades...

Demand served by end-use technology types (PJ)

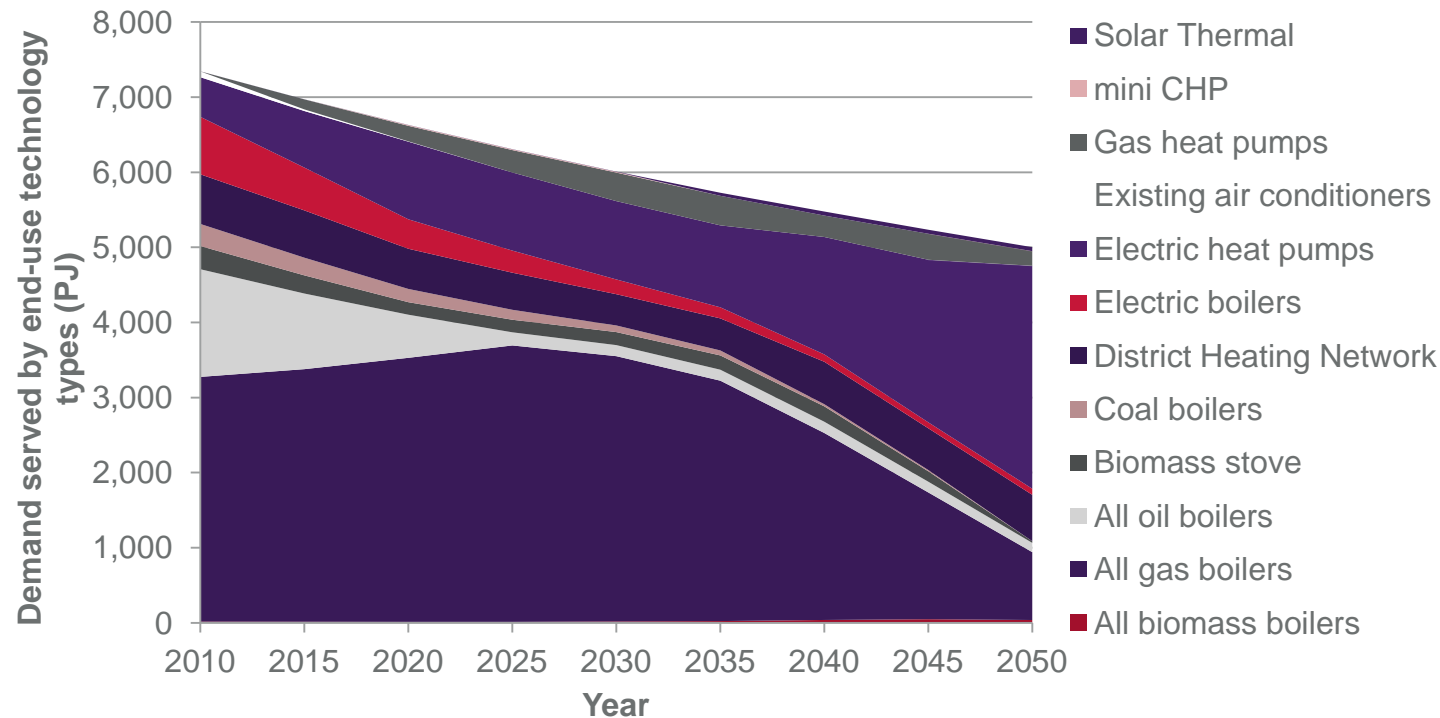

# CODEGen Model Flowchart

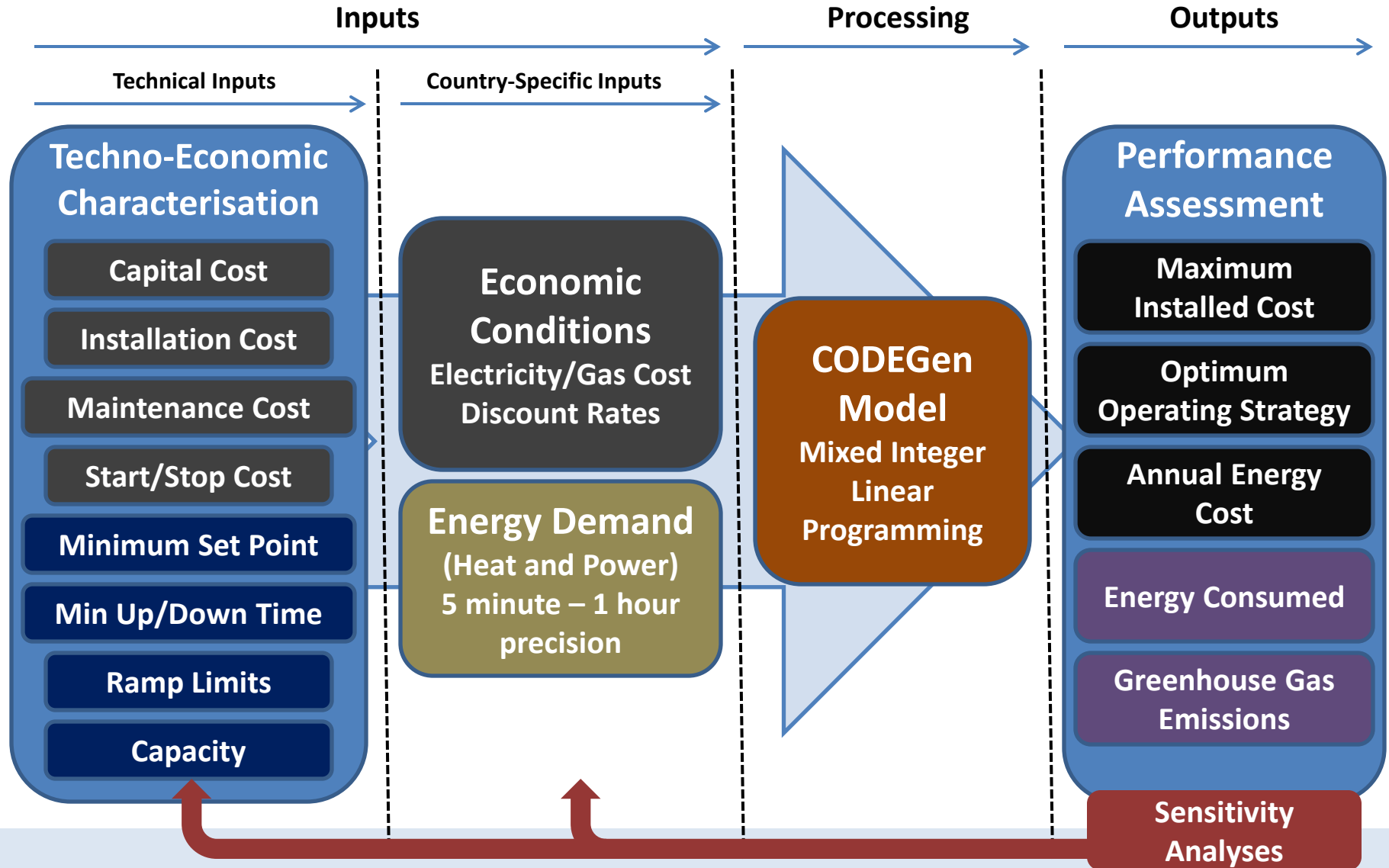

# Grounded in fuel cell engineering

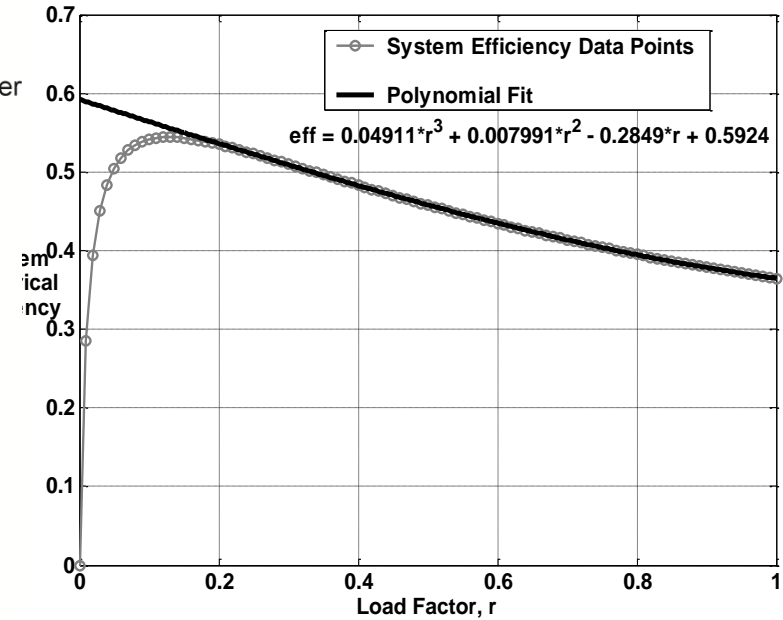
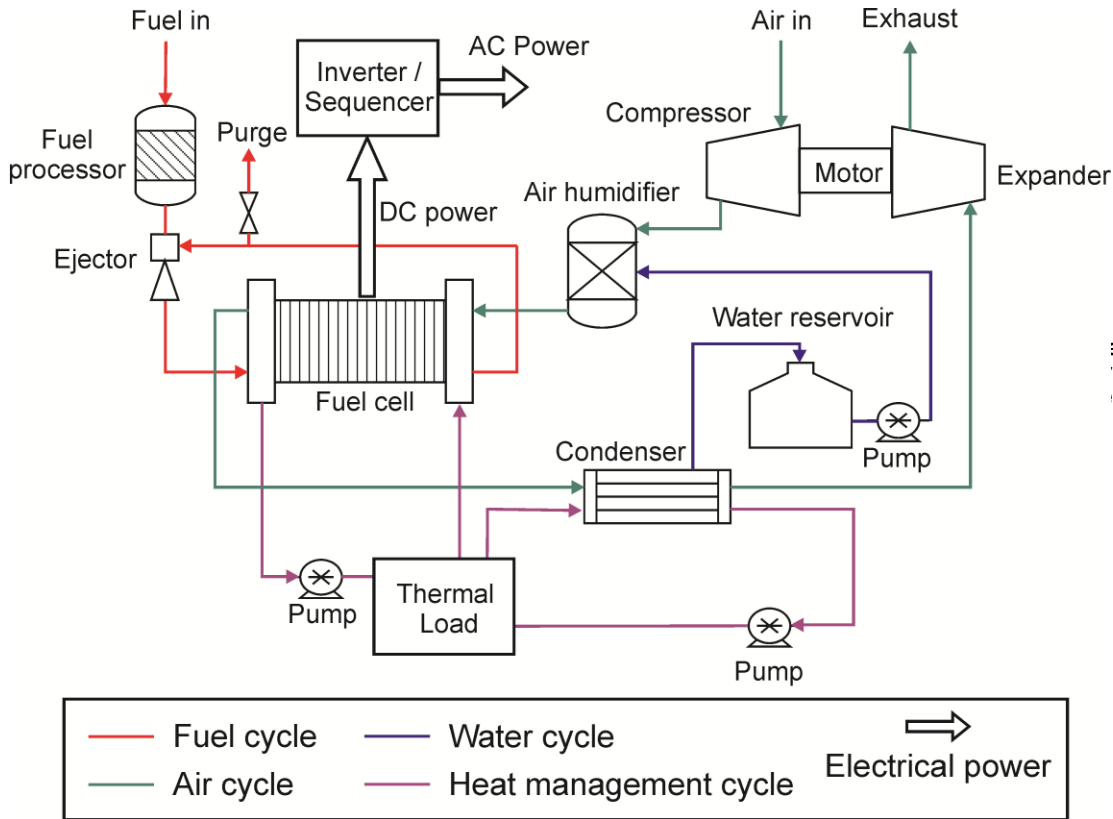

# Example application 1: Optimal Sizing

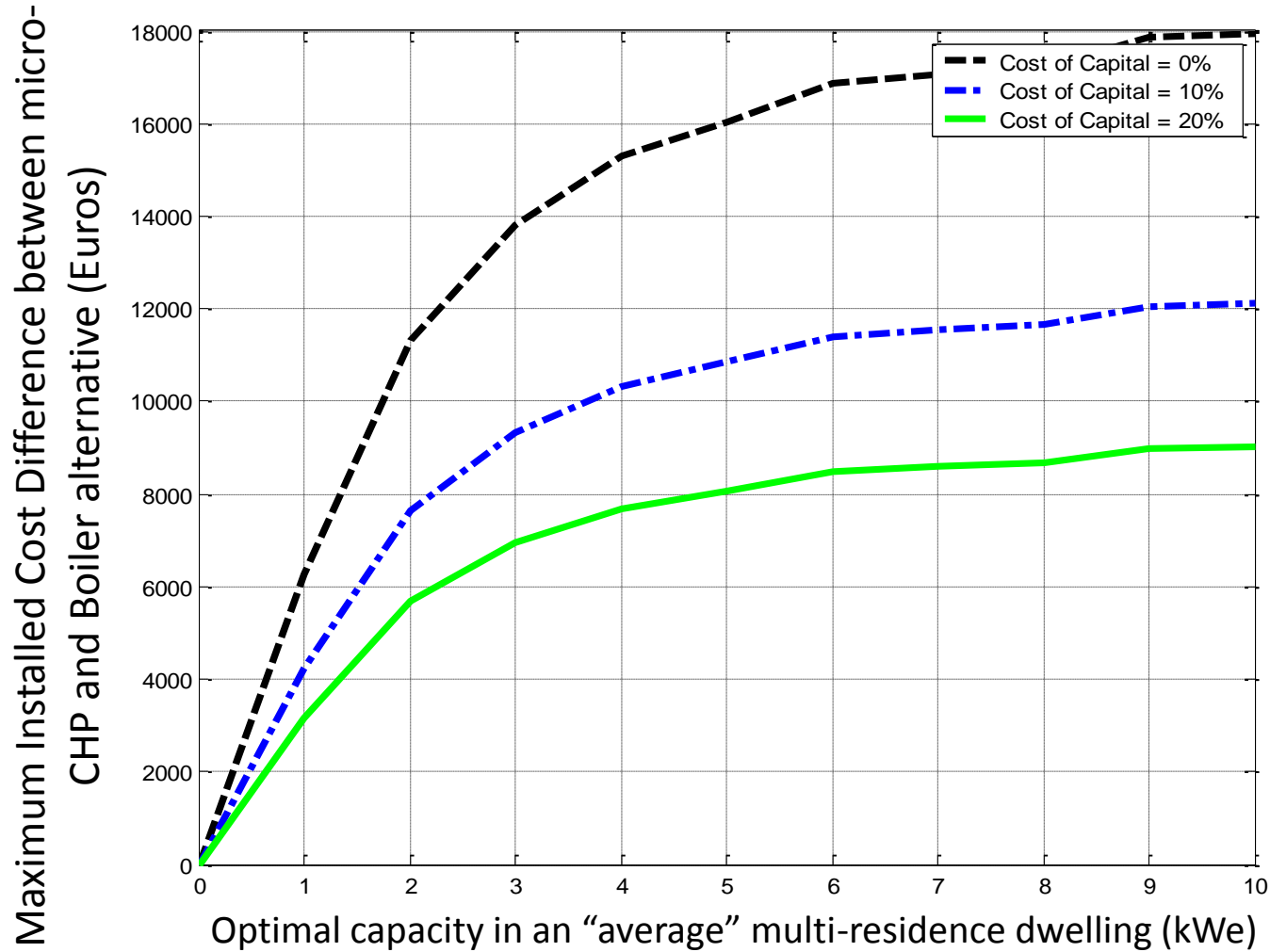

## Example application 2: Optimal Sizing + Thermal Energy Storage

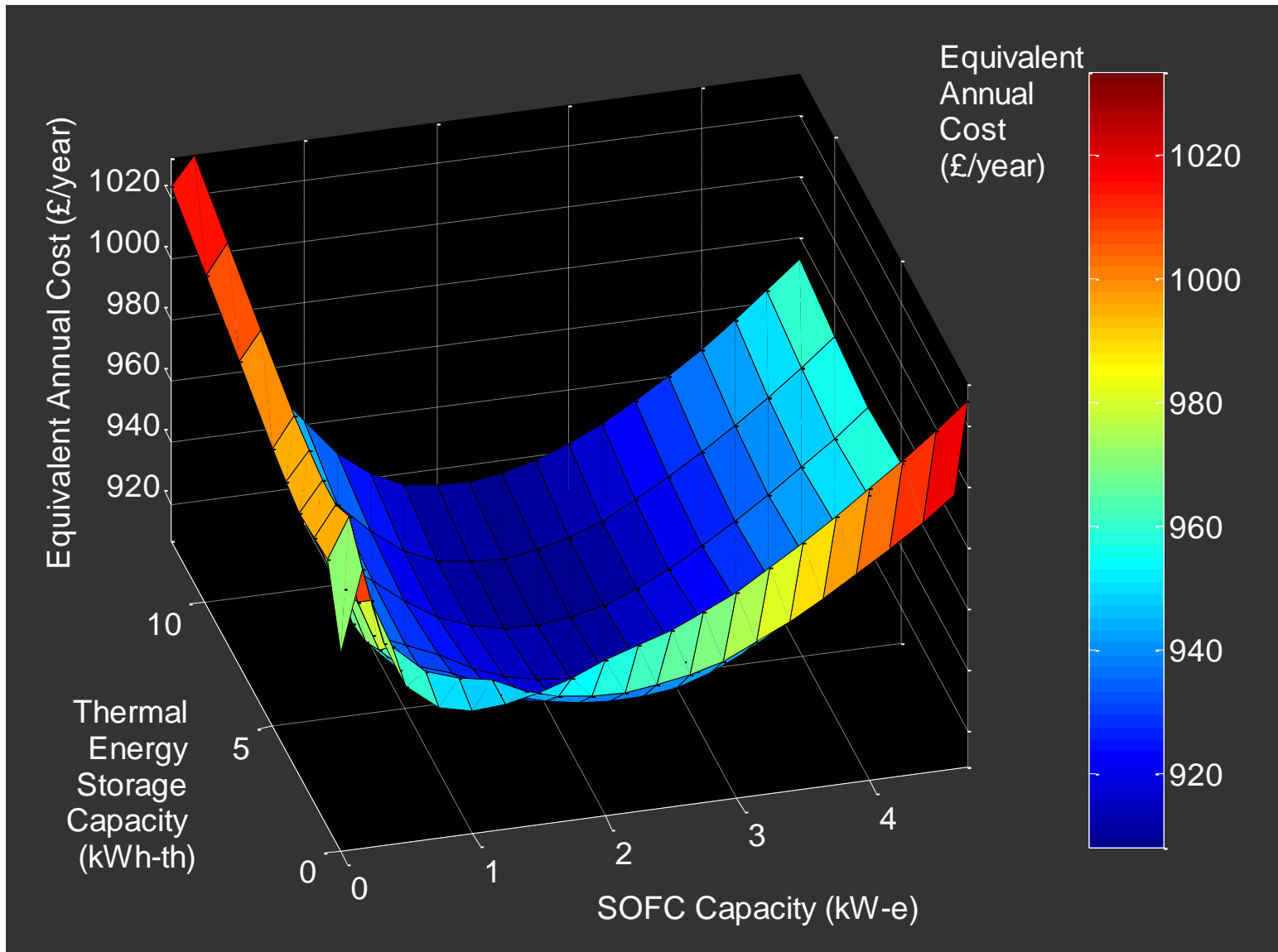

# Example application 3: Impact of Building Energy Efficiency (1)

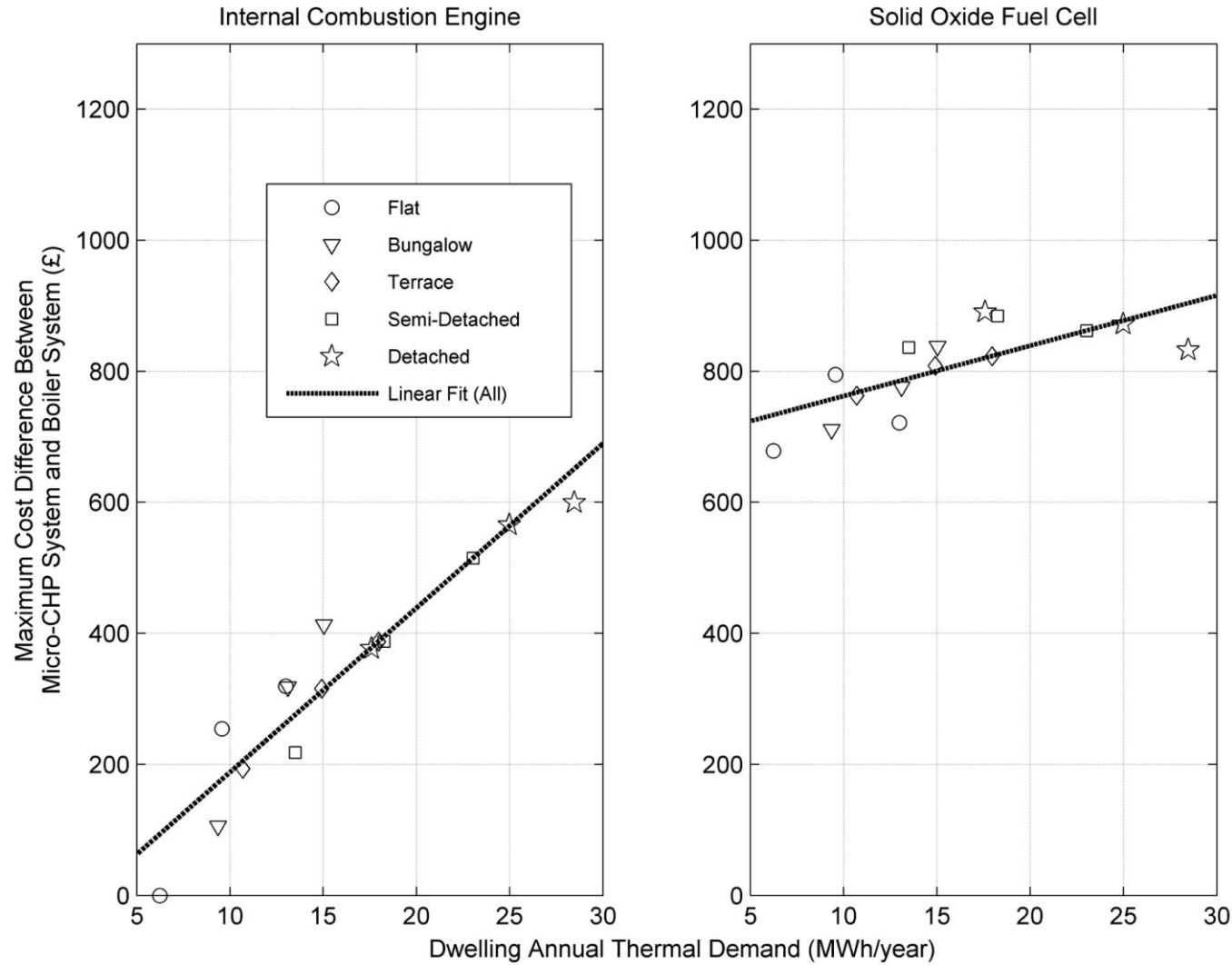

- Low heat-to-power ratio technologies are more “future-proof” in that they remain economically attractive under low thermal demand scenarios.

Source: A.D. Hawkes, I. Staffell, D.L. Brett, N.P. Brandon, (2009) Fuel Cells for Micro-Combined Heat and Power Generation. Energy & Environmental Science (Royal Society of Chemistry), 2(7) 729 - 744.

# Example application 4: Impact of Building Energy Efficiency (2)

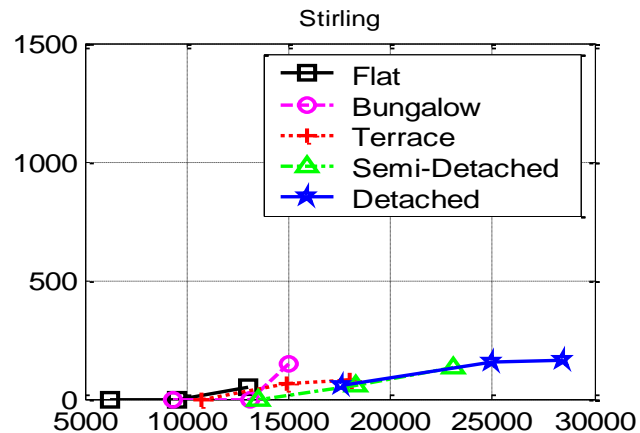
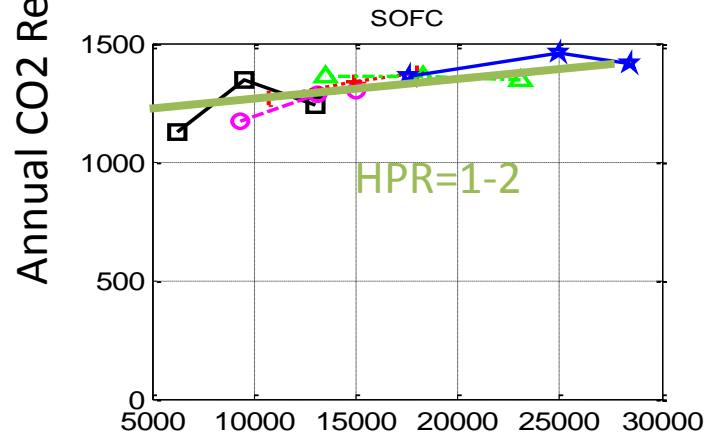
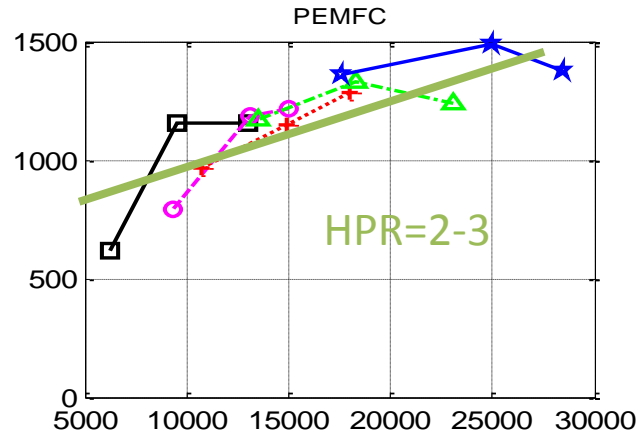
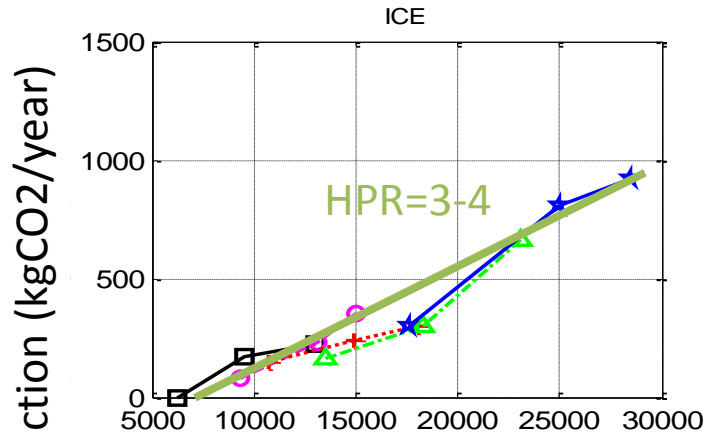

Annual Thermal Demand (kWh/year)

HPR = Heat-to-Power Ratio

# Example application 5: R&D Implications – Economics and Durability

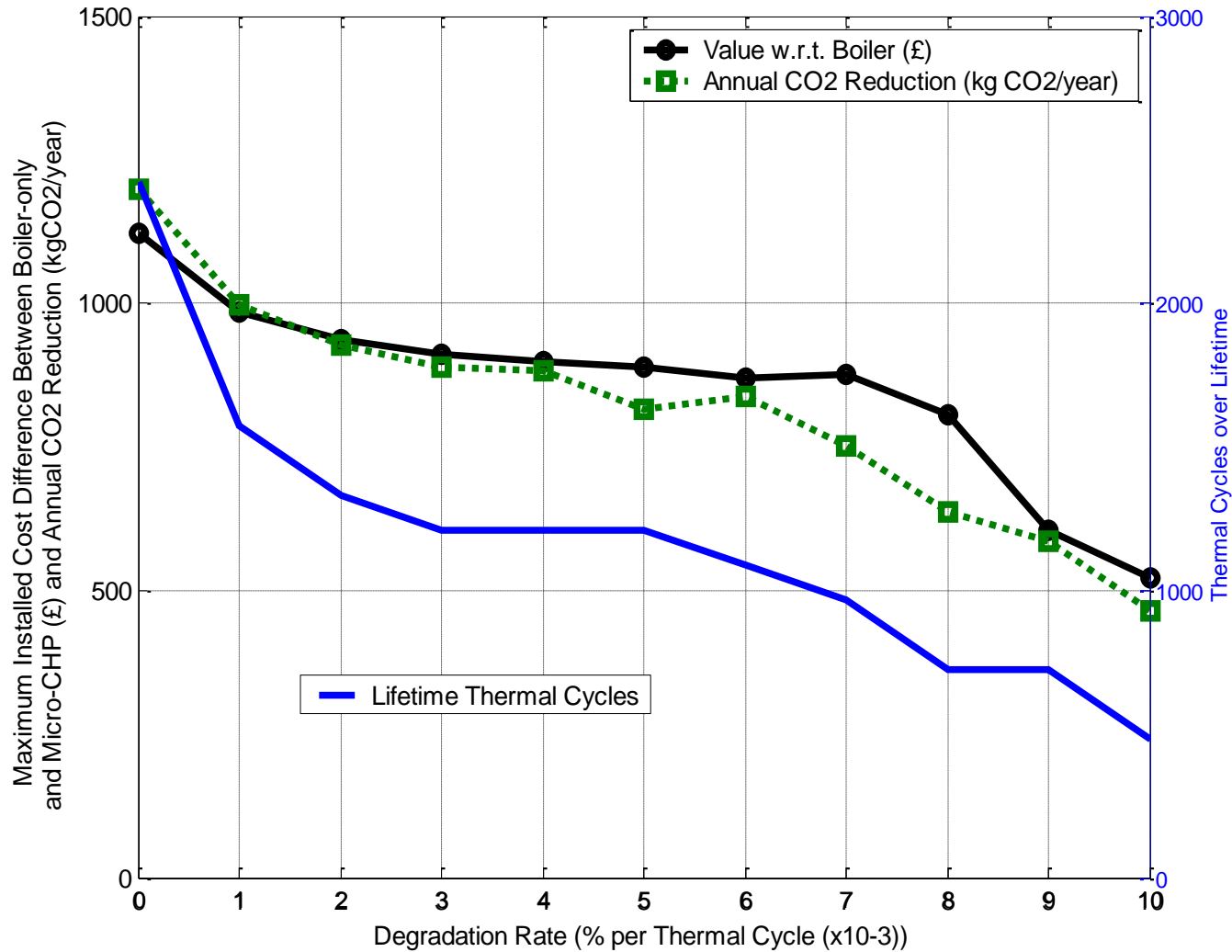

# Grid Interaction 1 – Short-run Marginal Emissions Factor (UK)

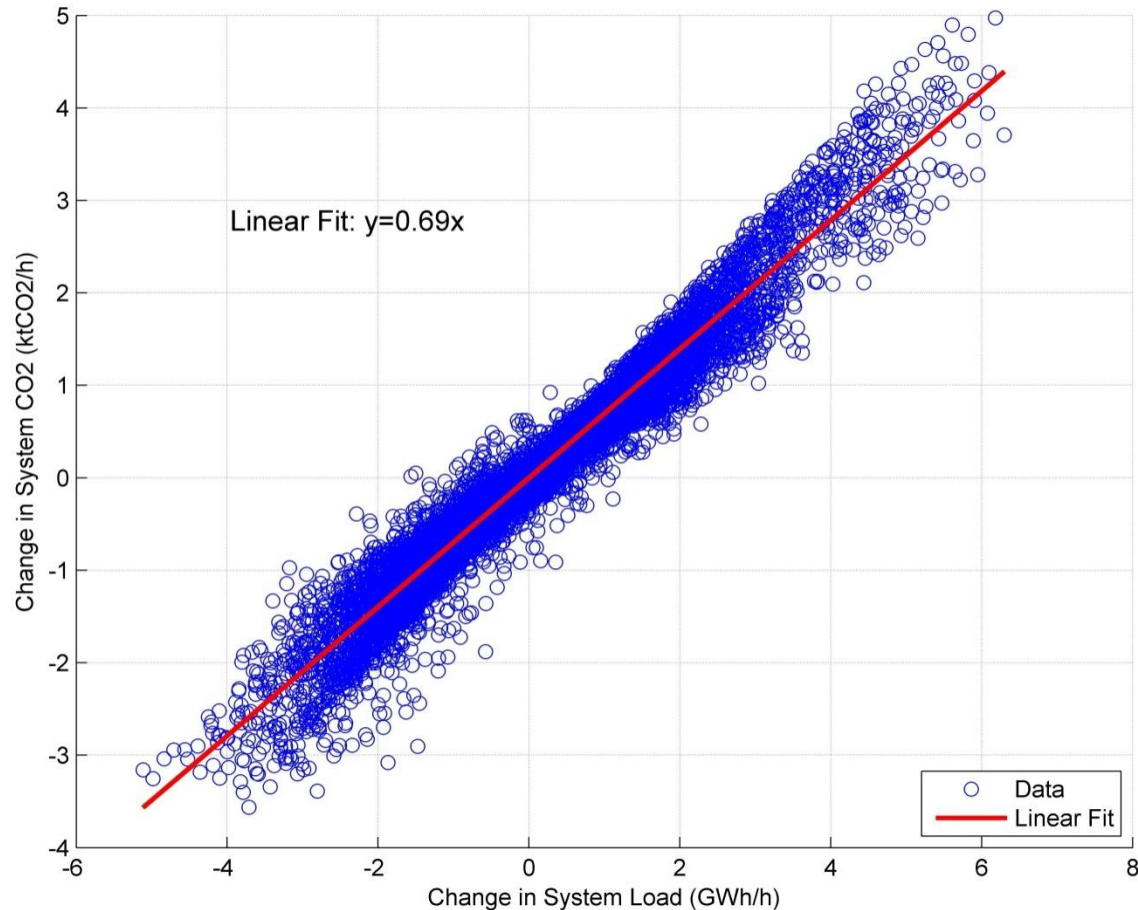

Hawkes (2010) Estimating Marginal CO2 Emissions Rates for National Electricity Systems. Energy Policy. Volume 38, Issue 10, October 2010, Pages 5977–5987

# Grid Interaction 2 – Long-run Marginal Emissions Factor (UK)

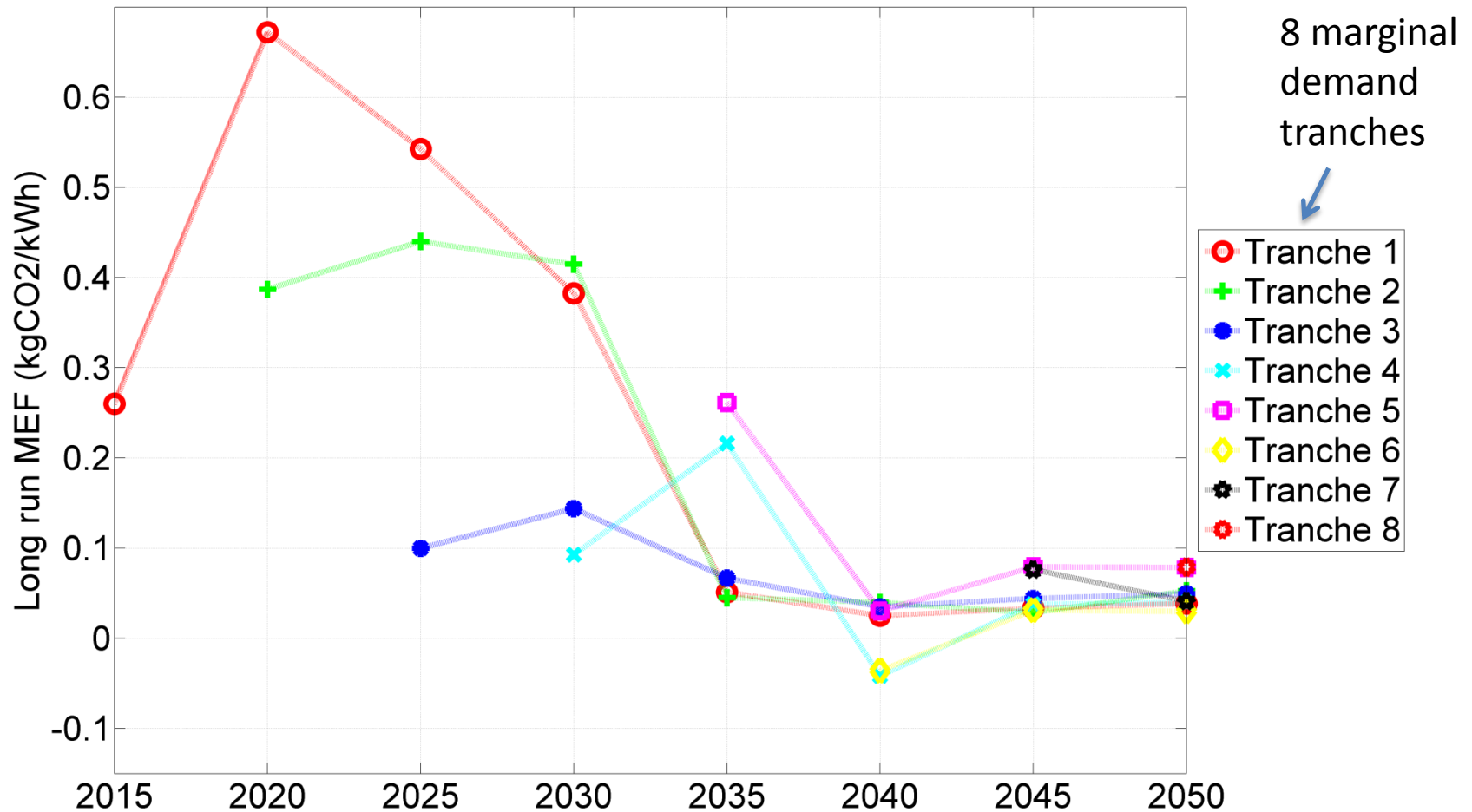

# Comparing emissions of end-use technologies

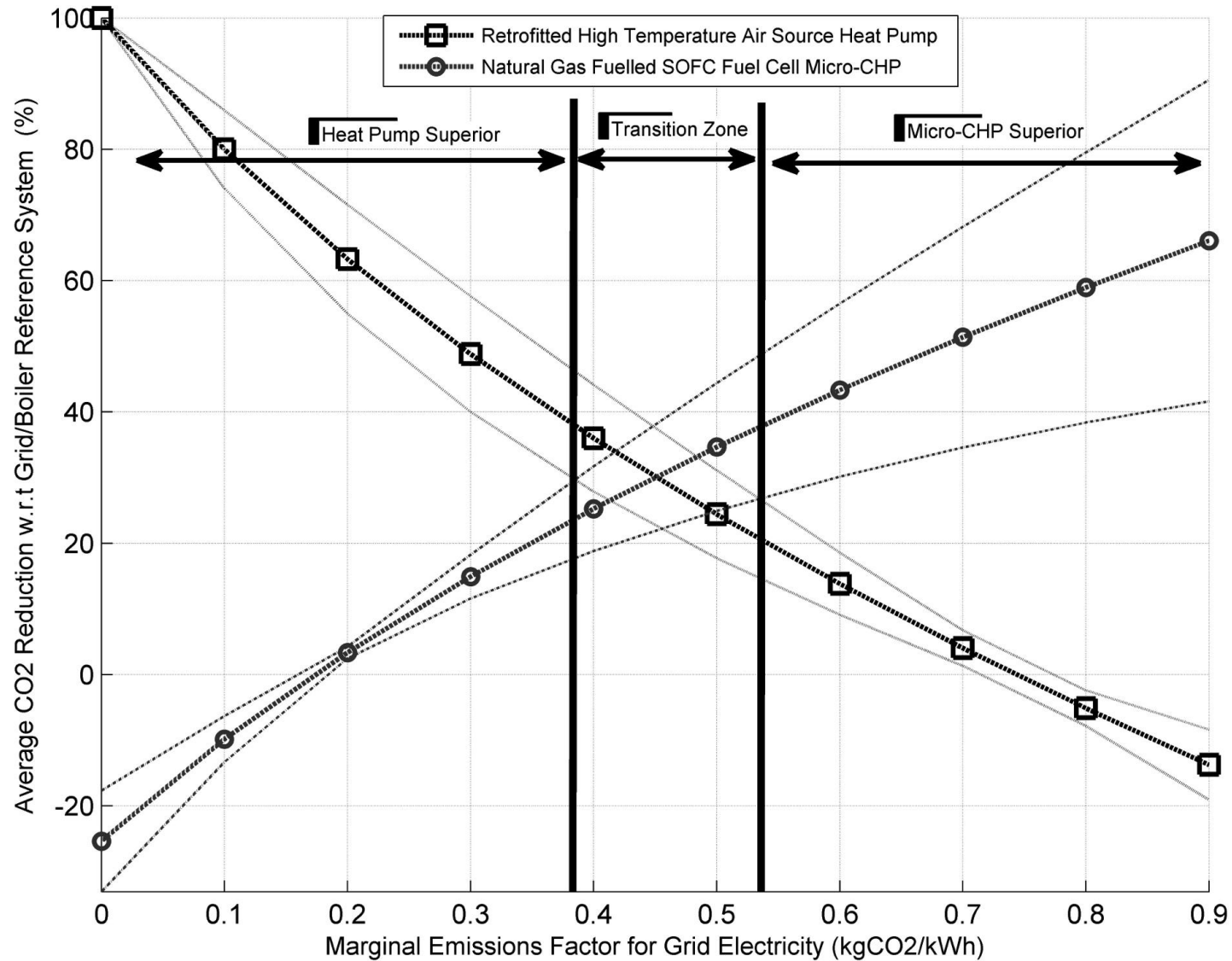

# Grid Interaction 3 – Micro-CHP and Heat Pumps

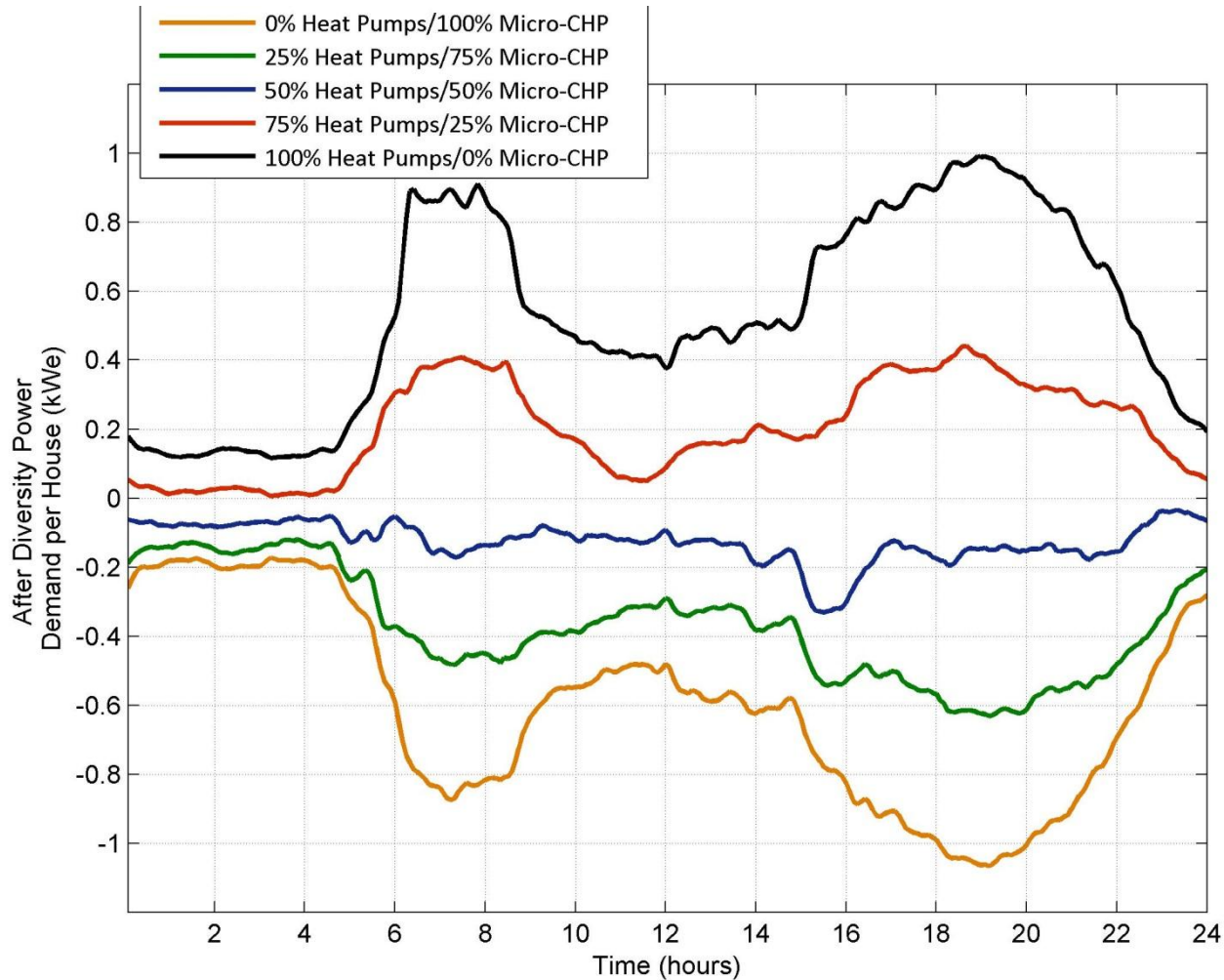

A D Hawkes, D J L Brett, and N P Brandon. Role of fuel cell based micro-cogeneration in low carbon heating. Proceedings of the Institution of Mechanical Engineers, Part A: Journal of Power and Energy 2011 225: 198-207

- Building from comprehensive assessment of micro-CHP interaction with buildings.
- Exploratory work on energy system interactions.
- Going forward:
- Comprehensive assessment of the role of micro-CHP in more integrated and coordinated energy systems.
  - Electricity infrastructure
  - Gas infrastructure
  - Energy efficiency trade-offs
  - Interactions between end-use technologies (design-stage)
  - Control (VPP, aggregation, droop control)
  - Arbitrage between energy vectors (electricity, gas, heat)
  - Assessment of technical interfaces